



Custom Cavity Sliding Door Systems

Table of Content

WELCOME	03
CLASSIC PRO PREMIUM	04
CLASSIC ZERO CLEARANCE	06
ALPRO ZC 60	08
GLYDA	10
SPACELINE	12
LADENKO TWINSLIDE & TRIPLE SLIDE	14
LADENKO KOMBO	15
LADENKO SORRENTO	16
DISABLED EZY-ACCESS DESIGN	17
CAVITY SET UP	18
CAVITY FINISHING KIT	20
SOFT CLOSE & JEXIS	21
CUSTOM DOORS	22

Welcome

B C Doors is a supplier of premium custom cavity sliding door systems, doors, and associated door products. Custom designed and manufactured to suit any application whether it is a project for high end residential, multi-residential, commercial, health or aged care. B C Doors extensive knowledge of our products and high levels of customer support ensures an effortless process.

Classic Pro Premium

Classic Pro offers a Kiln-Dried frame that delivers enhanced durability, increased space, and a variety of design options. With its extensive range of widths and heights available in three-unit configurations, it is well-suited for various applications, including floor-to-ceiling.

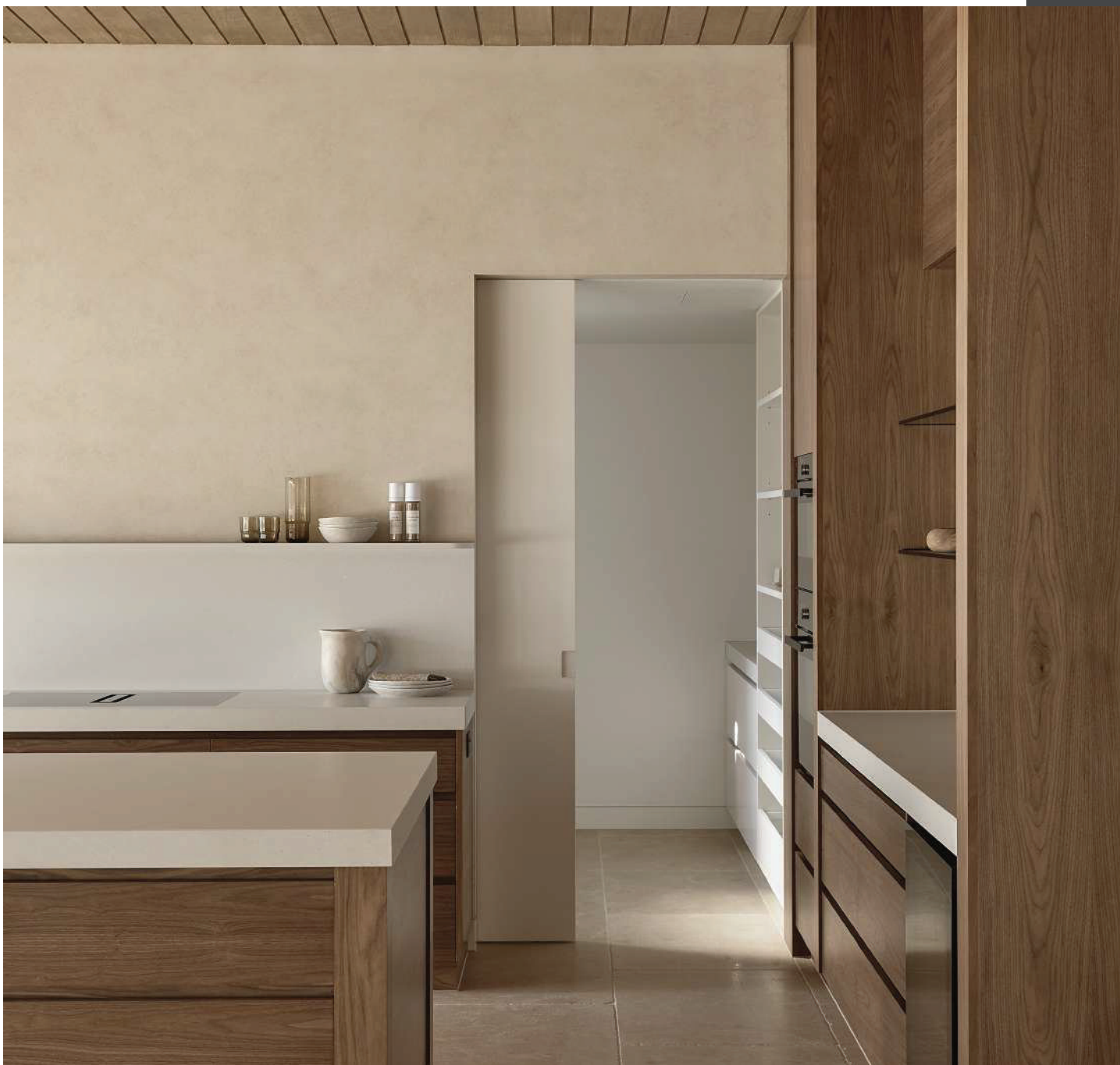



Features and Benefits

- Single piece aluminium Header track.
- Robust and reliable fittings.
- Select Grade timber.
- Available in Standard sizes.
- Option for Double Slider.
- Quick to install.

At a glance:

Max Door Weight	- 120kg
Max Door Width	- 1220mm
Max Door Height	- 2340mm
Min Door Thickness	- 35mm
Max Door Thickness	- 38mm
Max Stud width	- 90mm

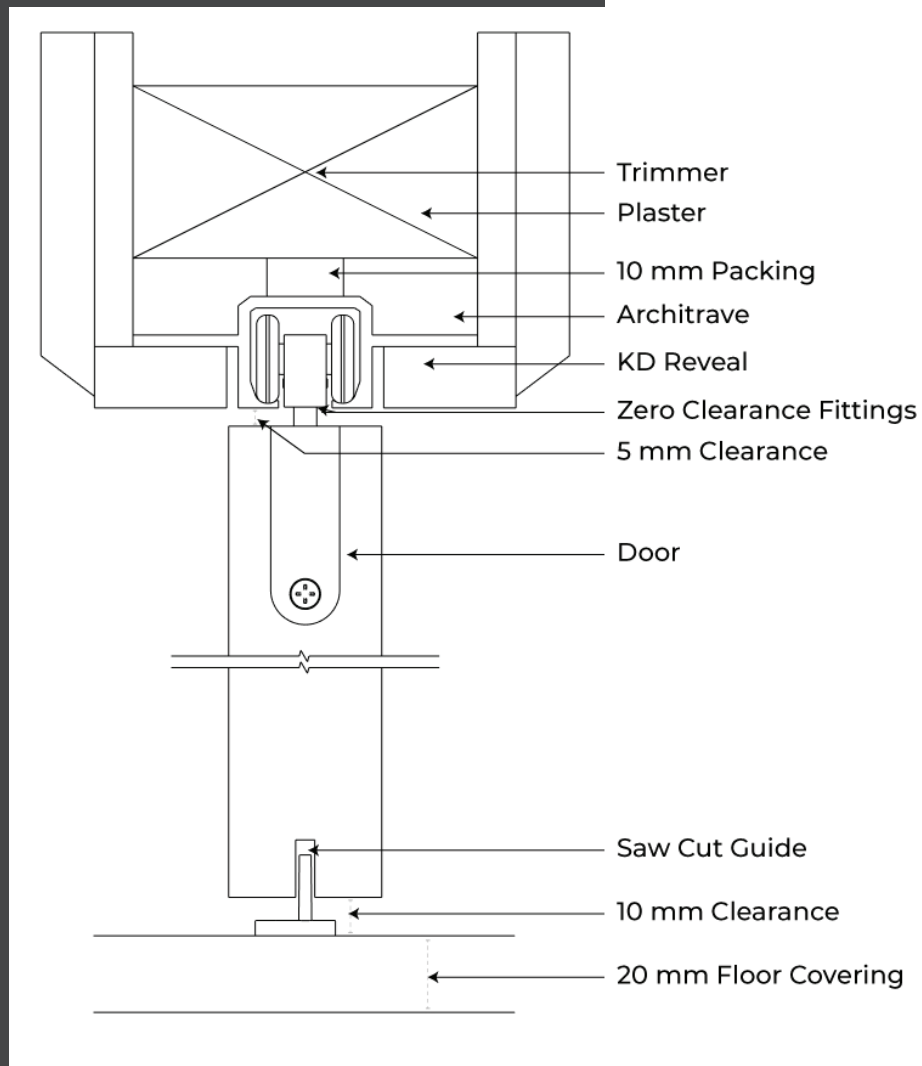

Classic Zero Clearance

Custom Architectural Cavity Sliding Door System

The Ladenko CLASSIC zero clearance sliding cavity door is meticulously designed to any specifications and constructed using premium select grade KD hardwood and features a robust extruded aluminium head track design that ensures a smooth and effortless operation.

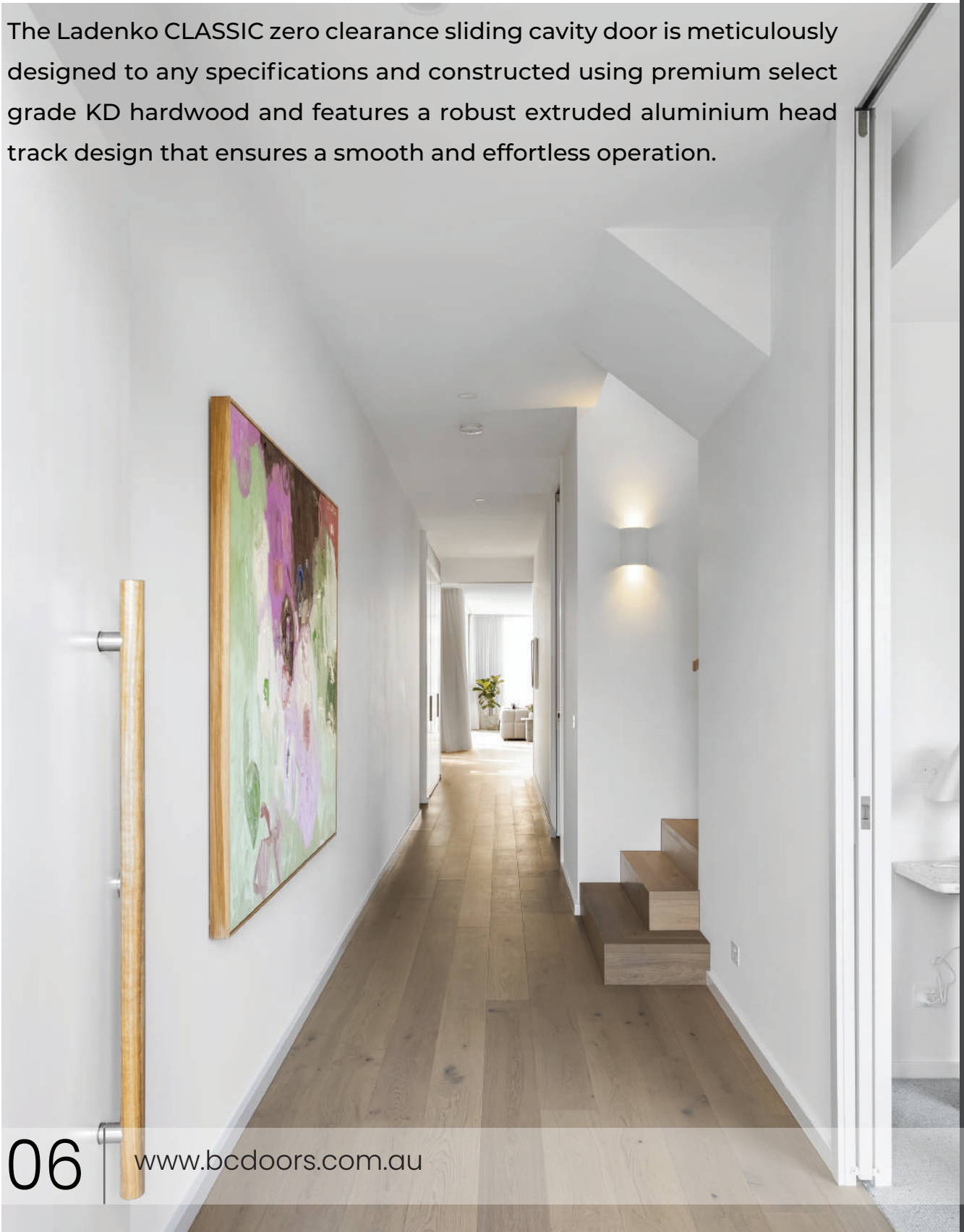



At a glance:

<i>Max Door Weight</i>	350kg
<i>Max Door Width</i>	Custom
<i>Max Door Height</i>	Custom
<i>Min Door Thickness</i>	35mm-Max
<i>Max Stud width</i>	Custom

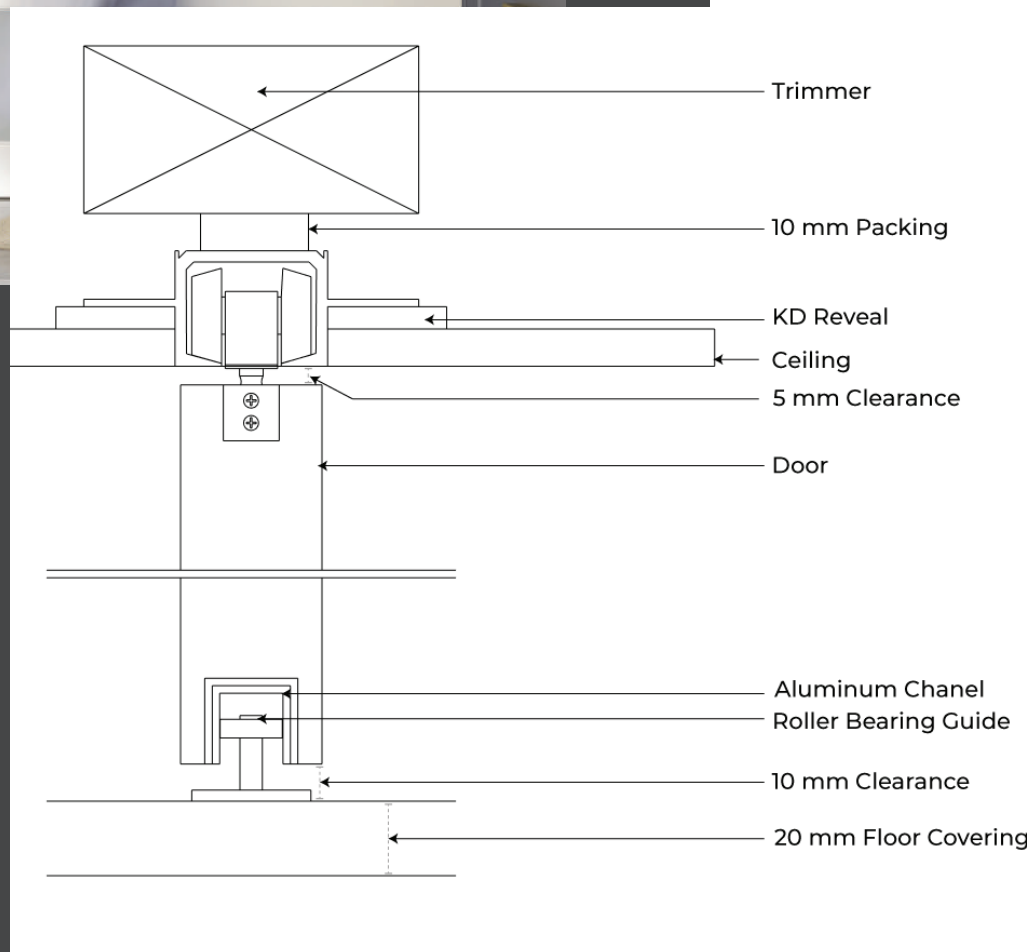

Features and Benefits

- *Custom Designed and Made to suit your project.*
- *Single piece aluminium Header track.*
- *Robust and reliable fittings.*
- *KD Hardwood.*
- *Option for Double Slider.*
- *Completely custom*

Alpro ZC 60

Standard Zero Clearance Cavity Sliding Door System

The Ladenko Alpro ZC 60 is a modern, architectural cavity door system with specially designed track and fittings which removes the need for pelmets. Available in standard sizes and designed with robust hardware with a capacity for doors up to 60kgs.



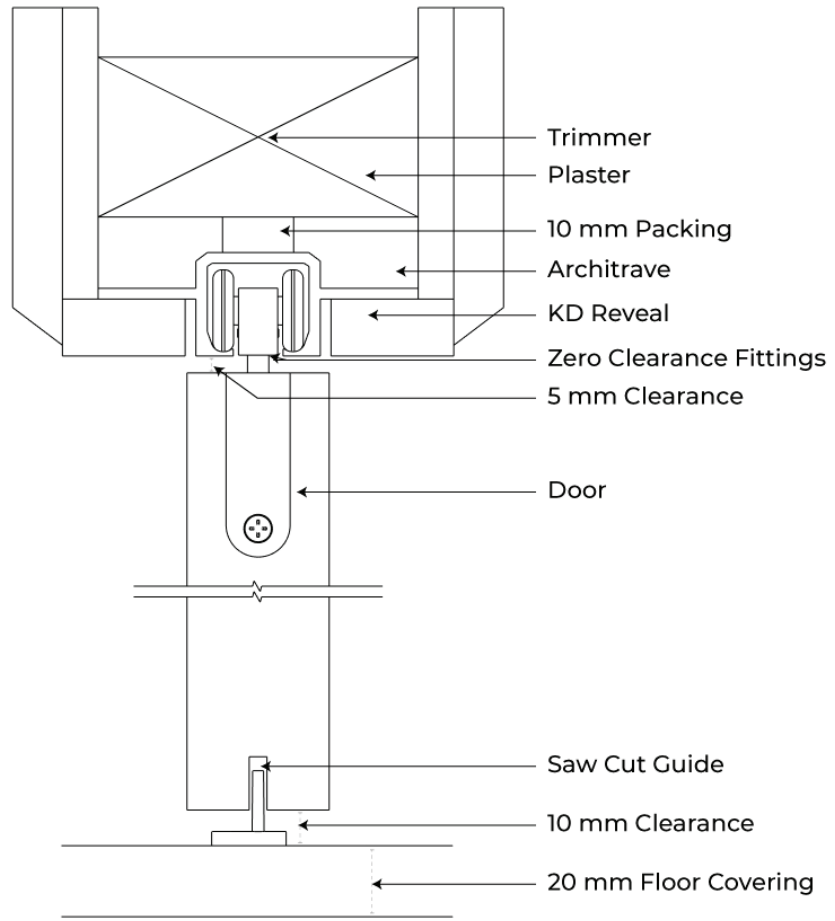

Features and Benefits

- Single piece aluminium Header track.
- Single or Double slider option
- Robust and reliable fittings.
- Select Grade pine timber.
- Available in Standard sizes.
- Option for Double Slider.

At a glance:

Max Door Weight	- 60kg
Max Door Width	- 1020mm
Max Door Height	- 2340mm
Min Door Thickness	- 35mm
Max Door Thickness	- 40mm
Max Stud width	- 90mm

GLYDA

Standard Cavity Sliding Door System.

The Ladenko GLYDA™ single and double cavity sliding door system is manufactured from high quality materials to stand the test of time. Designed for doors up to 60kg makes the GLYDA suitable for both residential and light commercial applications.



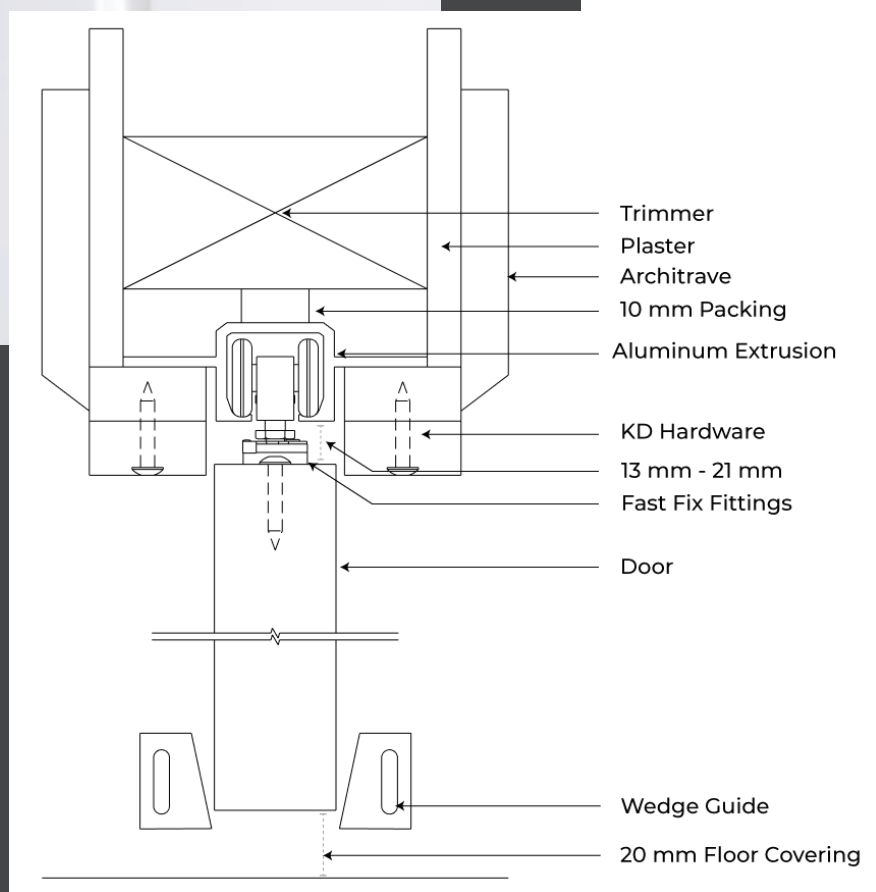

Features and Benefits

- Single piece aluminium Header track.
- Robust and reliable fittings.
- Select Grade timber.
- Available in Standard sizes.
- Option for Double Slider.
- Quick to install.

At a glance:

Max Door Weight	- 60kg
Max Door Width	- 1020mm
Max Door Height	- 2340mm
Min Door Thickness	- 35mm
Max Door Thickness	- 40mm
Max Stud width	- 90mm

Spaceline

Standard Cavity Sliding Door System.

Our Spaceline cavity frames have a detachable pelmet subsequently concealing the tracks and the door's top surface, resulting in a sleek and refined appearance.



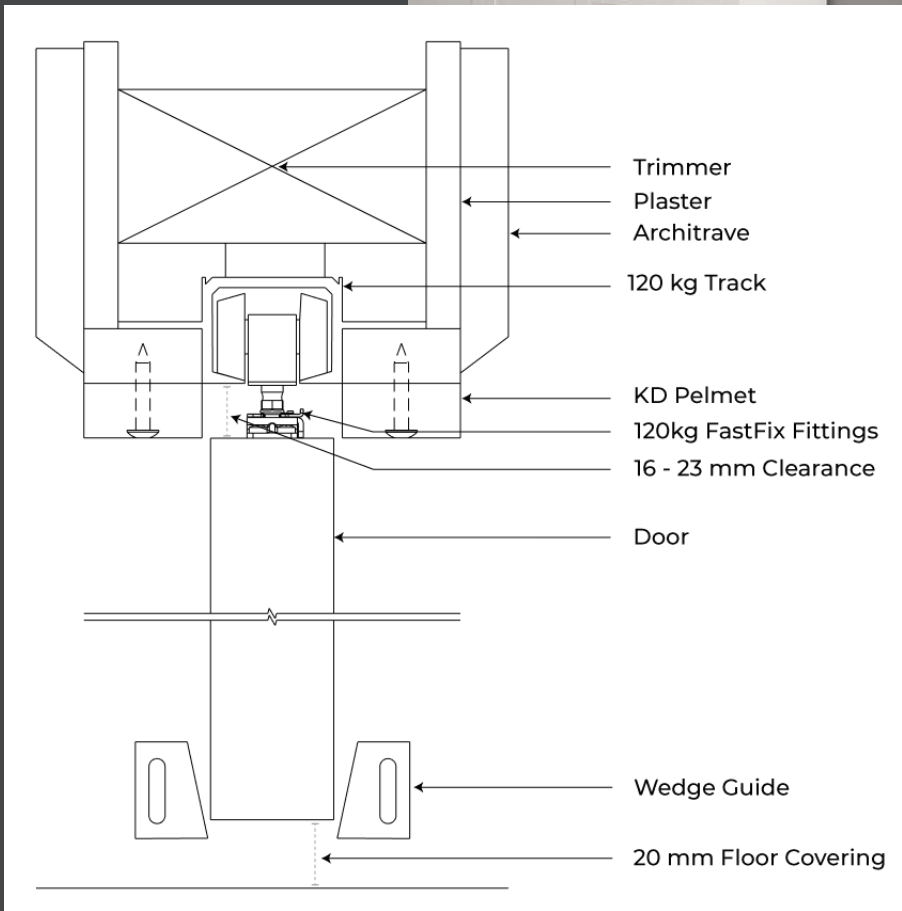

Features and Benefits

- Single piece aluminium Header track.
- Robust and reliable fittings.
- Select Grade timber.
- Available in Standard sizes.
- Option for Double Slider.
- Quick to install.

At a glance:

- | | |
|---------------------------|----------|
| <i>Max Door Weight</i> | - 120kg |
| <i>Max Door Width</i> | - 1220mm |
| <i>Max Door Height</i> | - 2340mm |
| <i>Min Door Thickness</i> | - 35mm |
| <i>Max Door Thickness</i> | - 38mm |
| <i>Max Stud width</i> | - 90mm |

Ladenko

TwinSlide & Triple Slide

The Ladenko TwinSlide (double overtaking doors) cavity sliding door system is ideal for space saving applications where you have a limited wall cavity space, but you need to maximise the walk-through opening as much as possible.



Ladenko

Kombo Cavity Sliding Door

The KOMBO Cavity Sliding Door System is the ultimate answer to your space-saving needs. This innovative solution allows you to optimize your available space by utilising a central wall cavity. Seamlessly accommodating two parallel sliding doors, which elegantly slide into the same central cavity sliding door frame.



Ladenko Sorrento

The Ladenko TwinSlide (double overtaking doors) cavity sliding door system is ideal for space saving applications where you have a limited wall cavity space, but you need to maximise the walk-through opening as much as possible.

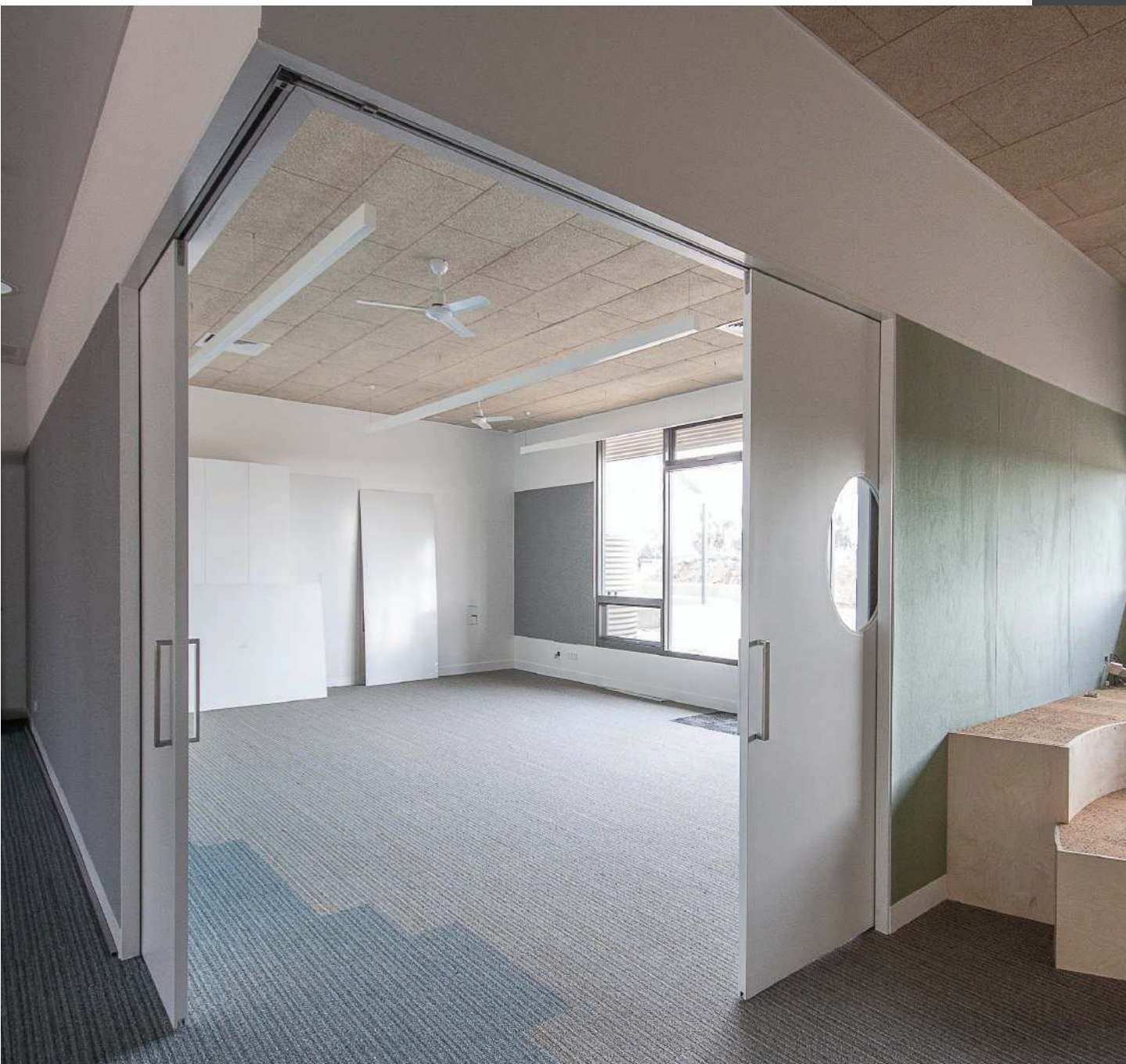

Disabled EZY-ACCESS Design

The Ladenko® EZY-Access cavity sliding door system is engineered with precision for the disabled that have physical limitations. Meticulously engineered to meet the requirements of the Disability Discrimination Act (DDA) and NCC Code.



Finishes

ARCHITRAVE

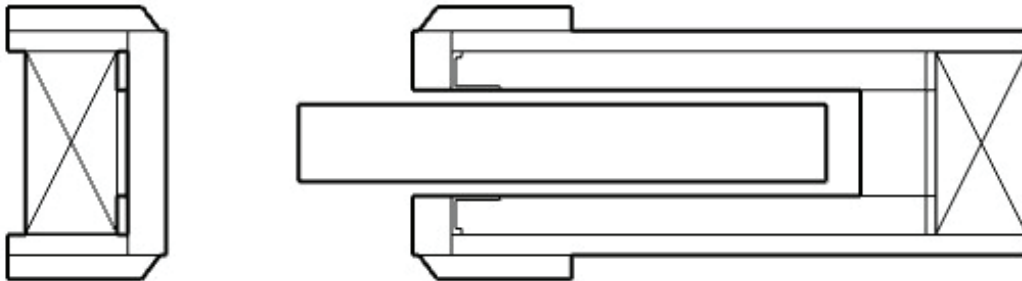

SQUARE SET



P50 SHADOWLINE



Finishes that are available on the Ladenko Range.

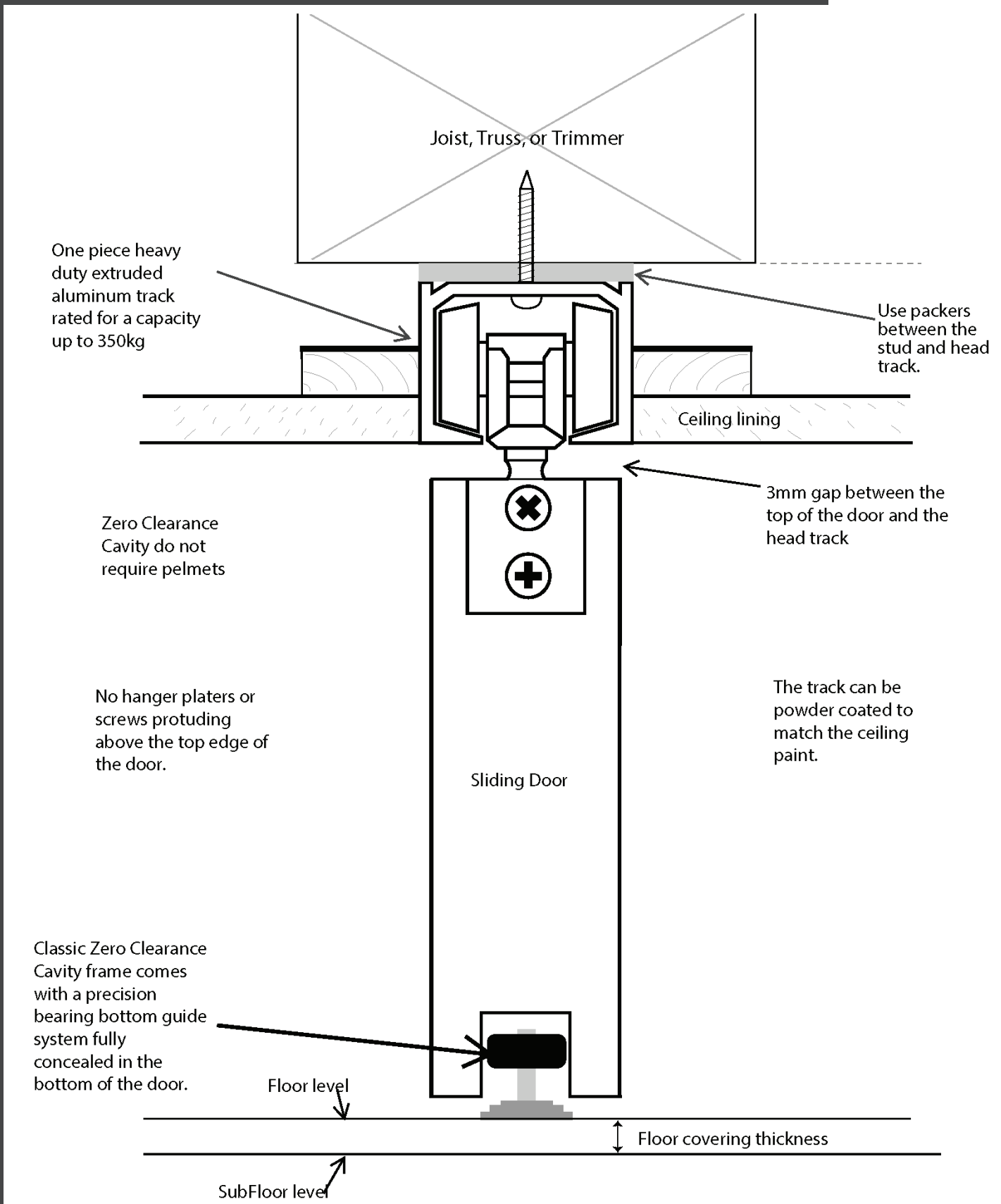

Cavity Finishing Kit

By Utilizing the Cavity Finishing Kit, you can achieve a square flush appearance as the system effortlessly conceals any gaps or rough edges that would typically be visible. The Cavity Finishing Kit is incredibly easy and quick to install saving you time and money.

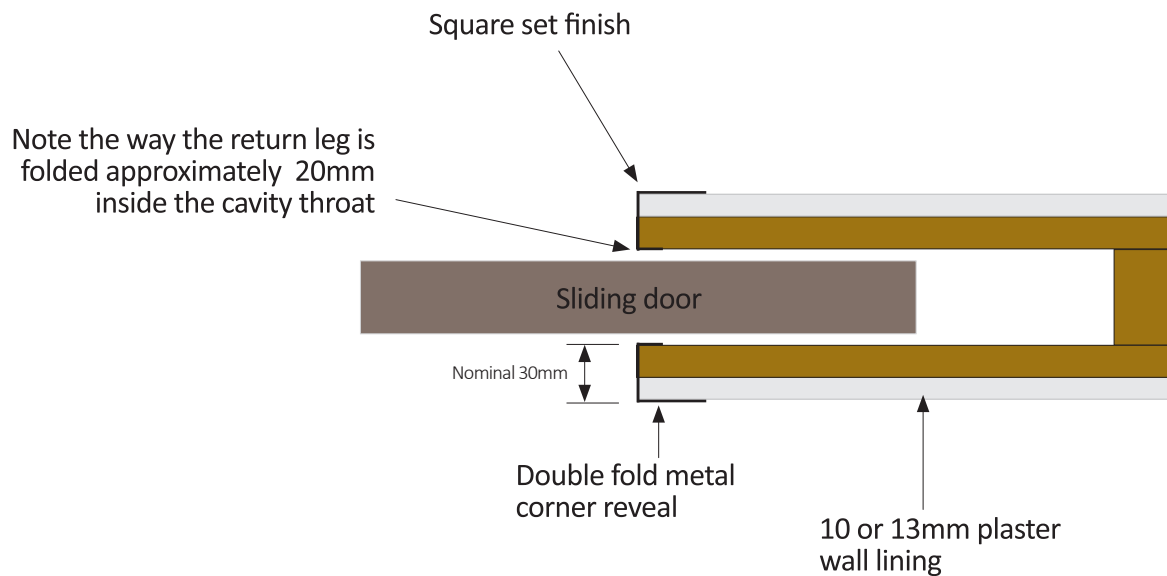

Soft Close

The soft close mechanism is engineered to provide a refined experience for cavity doors. This intelligent system adeptly captures the door's motion, gradually reducing its speed and guiding it towards the jamb with precision, guaranteeing a consistently quiet and gentle stop. The deliberate deceleration not only prevents disruptive door slamming but also ensures the utmost safety for little fingers, exemplifying our commitment to creating secure & serene environments.

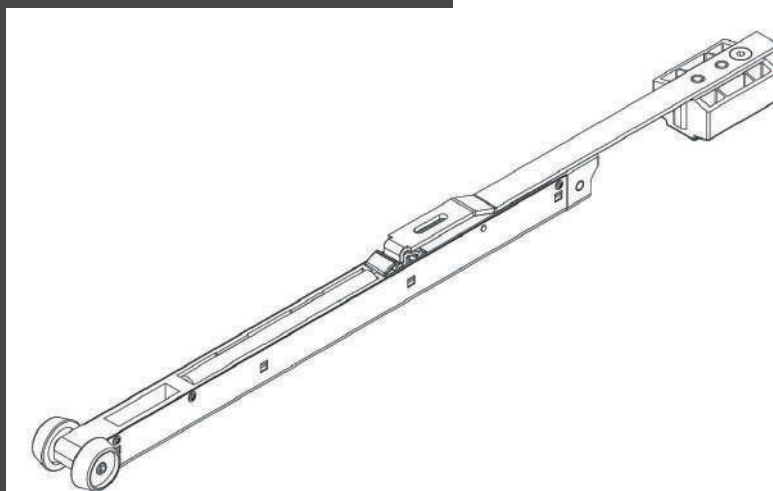

Jexis

The Jexis Door Ejector is an ingenious solution that eliminates the need for clumsy door clasps on cavity doors. Neatly fitted to the hidden edge of your doors, this sleek design operates with a press-release mechanism, ensuring quiet and seamless operation. Say goodbye to inconvenience and embrace the tranquil convenience of the Jexis Door Ejector, where simplicity meets sophistication in a whisper-quiet experience.



Custom Doors

Wide selection of bespoke doors to suit your custom-made cavity slider, our commitment to excellence extends beyond aesthetics. We understand the importance of durability, and energy efficiency. That's why our doors are built to meet and exceed industry standards, offering you peace of mind and long-lasting performance.

- Flush Panel Doors
- Joinery Doors
- Pivot Doors

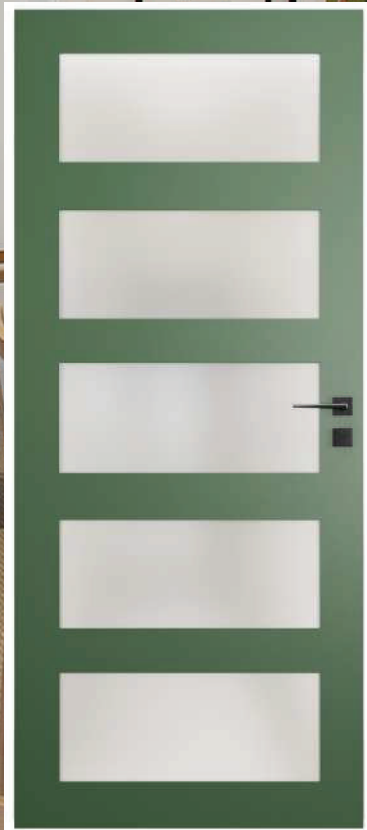

Contact Us -



For Sales and Technical Enquiries,
please contact BC Doors

Email

sales@bcdoors.com.au

Phone

1300 360 181

Address

52 – 56 Produce Drive
Dandenong South Victoria 3175

www.bcdoors.com.au